

Diaphragm Valve, Metal

Construction

The GEMÜ 687 pneumatically operated 2/2-way diaphragm valve has a low maintenance actuator. Normally Closed, Normally Open and Double Acting control functions are available.

Features

- Suitable for inert and corrosive* liquid and gaseous media
- Chemical resistance of actuator
- Stainless steel body with CIP/SIP cleaning and sterilising capabilities
- Insensitive to particulate media
- Valve body and diaphragm available in various materials and designs
- Various connections available
- Surface finishes down to 10 µinch, electropolished
- Versions according to ATEX on request
- Optical position indicator is standard for control function 1

Advantages

- The modular actuator system permits a variety of options to be used such as tank bottom valves, T valves, sampling valves, multi-port valves and tandem welded configurations
- Optional flow direction
- Installation for an optimized draining is possible
- Optional accessories:
 - Stroke limiter
 - Optical position indicator control function 2 + 3
 - Manual override (GEMÜ 1002, GEMÜ 1004)
 - Pilot valve with manual override (GEMÜ 0322 - 0326)
 - Electrical position indicators

*see information on working medium on page 2



Sectional drawing

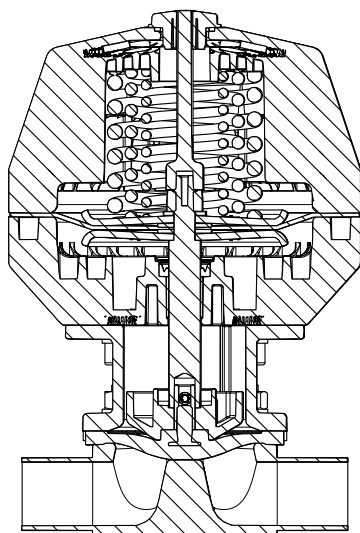

Technical data

Working medium

Corrosive, inert, gaseous and liquid media which have no negative impact on the physical and chemical properties of the body and diaphragm material.

Temperatures

Medium temperature

FKM (code 4)	14 ... 194 °F
EPDM (code 13)	14 ... 212 °F
EPDM (code 29)	14 ... 212 °F
EPDM (code 17)	14 ... 212 °F
PTFE/EPDM (code 54)	14 ... 212 °F
PTFE/EPDM (code 5M)	14 ... 212 °F

Sterilisation temperature ⁽¹⁾

FKM (code 4)	not applicable
EPDM (code 13)	max. 302 °F ⁽²⁾ , max. 60 min per cycle
EPDM (code 29)	not applicable
EPDM (code 17)	max. 302 °F ⁽²⁾ , max. 180 min per cycle
PTFE/EPDM (code 54)	max. 302 °F ⁽²⁾ , no time limit per cycle
PTFE/EPDM (code 5M)	max. 302 °F ⁽²⁾ , no time limit per cycle

¹ The sterilisation temperature is valid for steam (saturated steam) or superheated water.

² If the sterilisation temperatures listed above are applied to the EPDM diaphragms for longer periods of time, the service life of the diaphragms will be reduced. In these cases, maintenance cycles must be adapted accordingly. This also applies to PTFE diaphragms exposed to high temperature fluctuations.

PTFE diaphragms can also be used as moisture barriers; however, this will reduce their service life.

The maintenance cycles must be adapted accordingly.

GEMÜ 555 and 505 globe valves are particularly suitable for use in the area of steam generation and distribution.

The following valve arrangement for interfaces between steam pipes and process pipes has proven itself over time:

A globe valve for shutting off steam pipes and a diaphragm valve as an interface to the process pipes.

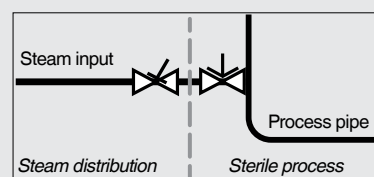

Ambient temperature

32 ... 140 °F

Control medium

Inert gases

Max. permissible temperature of control medium

104 °F

Filling volume

Actuator size	Control function 1	Control function 2
B/N	1.83 cinch	1.22 cinch
1/N	9.15 cinch	6.71 cinch
F/M	12.2 cinch	-
F/N	12.2 cinch	9.76 cinch
2/N	15.87 cinch	14.04 cinch
H/M	25.63 cinch	-
H/N	25.63 cinch	24.41 cinch
3/N	44.55 cinch	32.95 cinch
J/M	48.21 cinch	-
J/N	48.21 cinch	42.11 cinch
4/N	140.36 cinch	114.11 cinch
5/N	140.36 cinch	122.05 cinch

C.f. 3 = for filling volume in open position see c.f. 1, for filling volume in closed position see c.f. 2

Technical data

MG	DN	Actuator size	Operating pressure [psi]				Control pressure [psi]		
			Control function 1		Control function 2 + 3		Control function 1	Control function 2	Control function 3
			EPDM / FKM	PTFE	EPDM / FKM	PTFE			
10	10, 15, 20	B/N	0 - 150	0 - 90	0 - 90	0 - 90	51 - 102	max. 87	max. 73
25	15, 20, 25	1/N	0 - 150	0 - 90	0 - 150	0 - 90	80 - 102	max. 80	max. 80
		F/M	0 - 90	0 - 90	-	-	55 - 87	-	-
		F/N	0 - 150	0 - 150	0 - 150	0 - 150	80 - 102	max. 80	max. 80
40	32, 40	2/N	0 - 150	0 - 90	0 - 150	0 - 90	80 - 102	max. 80	max. 80
		H/M	0 - 90	0 - 90	-	-	55 - 87	-	-
		H/N	0 - 150	0 - 150	0 - 150	0 - 150	80 - 102	max. 80	max. 80
50	50, 65	3/N	0 - 150	0 - 90	0 - 150	0 - 90	80 - 102	max. 73	max. 73
		J/M	0 - 90	0 - 90	-	-	55 - 87	-	-
		J/N	0 - 150	0 - 150	0 - 150	0 - 150	80 - 102	max. 73	max. 73
80	65, 80	4/N	0 - 120	0 - 75	0 - 120	0 - 90	80 - 102	max. 73	max. 65
		6A	-	-	-	0 - 150	-	max. 44	max. 44
		6A2	-	0 - 150	-	-	58 - 102	-	-
100	100	5/N	0 - 90	0 - 60	0 - 90	0 - 60	80 - 102	max. 73	max. 65
		7A	-	-	-	0 - 150	-	max. 51	max. 51
		7A3	-	0 - 150	-	-	65 - 102	-	-

MG = diaphragm size

All pressures are gauge pressures. Operating pressure values were determined with static operating pressure applied on one side of a closed valve. Sealing at the valve seat and atmospheric sealing is ensured for the given values. Information on operating pressures applied on both sides and for high purity media on request. Higher operating pressures on request.

Cv values [gpm]

Pipe standard	DIN	EN 10357 series B (formerly DIN 11850 series 1)	EN 10357 series A (formerly DIN 11850 series 2) / DIN 11866 series A	DIN 11850 series 3	SMS 3008	ASME BPE / DIN 11866 series C	ISO 1127 / EN 10357 series C / DIN 11866 series B	DIN ISO 228	NPT	
Connection code	0	16	17	18	37	59	60	1	31	
MG	DN									
10	10	-	2.8	2.8	2.8	-	2.6	3.9	-	-
	12	-	-	-	-	-	-	-	3.7	-
	15	3.9	4.4	4.4	4.4	-	2.6	4.7	4.0	-
	20	-	-	-	-	-	4.4	-	-	-
25	15	4.8	5.5	5.5	5.5	-	-	8.7	7.6	7.6
	20	7.4	8.2	8.2	8.2	-	5.1	15.4	11.7	11.7
	25	16.3	17.5	17.5	17.5	14.7	14.3	19	16.4	16.4
40	32	29.6	31.6	31.6	31.6	30.7	-	35.1	30.4	30.4
	40	34.3	36.2	36.2	36.2	35.3	34.5	38.4	38.6	38.6
50	50	54.4	56.6	56.6	56.6	60.5	59.2	64.6	70.2	70.2
	65	-	-	-	-	72.8	72.3	-	-	-
80	65	-	-	90.1	-	80.1	80.1	112.3	-	-
	80	-	-	129.9	-	93.6	101.8	129.9	-	-
100	100	-	-	227.0	-	202.4	220.0	250.4	-	-

MG = diaphragm size

Cv values determined acc. to inlet pressure 75 psi, Δp 1 psi, stainless steel valve body (forged body) and soft elastomer diaphragm.

The Cv values for other product configurations (e.g. other diaphragm or body materials) may differ. In general, all diaphragms are subject to the influences of pressure, temperature, the process and their tightening torques. Therefore the Cv values may exceed the tolerance limits of the standard.

The Kv value curve (Kv value dependent on valve stroke) can vary depending on the diaphragm material and duration of use.

Technical data

Control pressure / operating pressure diagram

Control function 2 + 3 with elastomer diaphragm

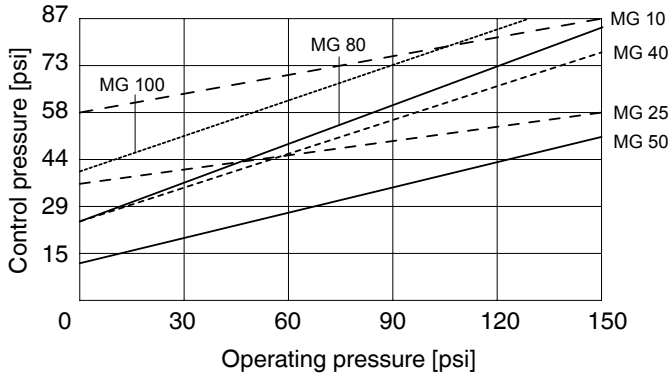

Control function 2 + 3 with PTFE diaphragm

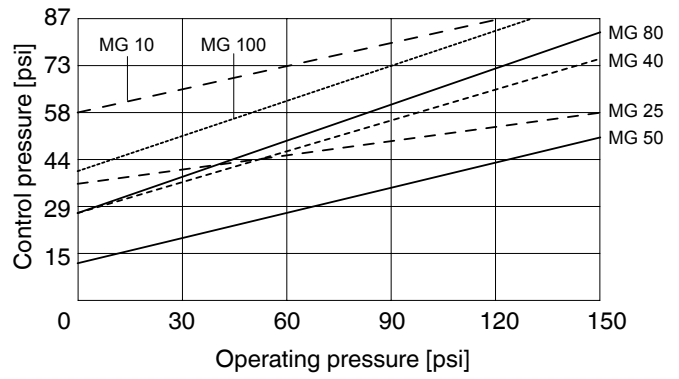

Control function 2 + 3 with elastomer diaphragm

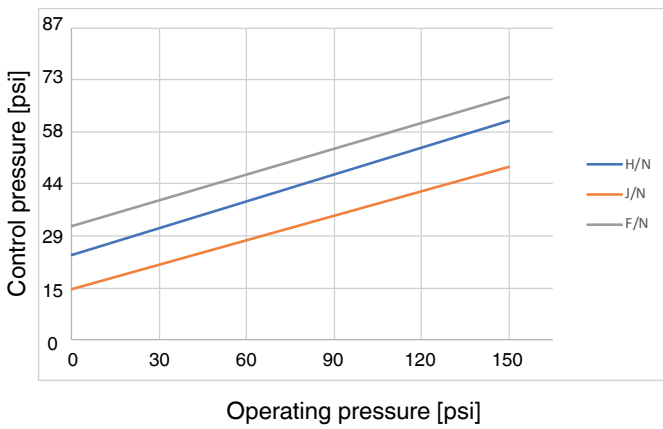

Control function 2 + 3 with PTFE diaphragm

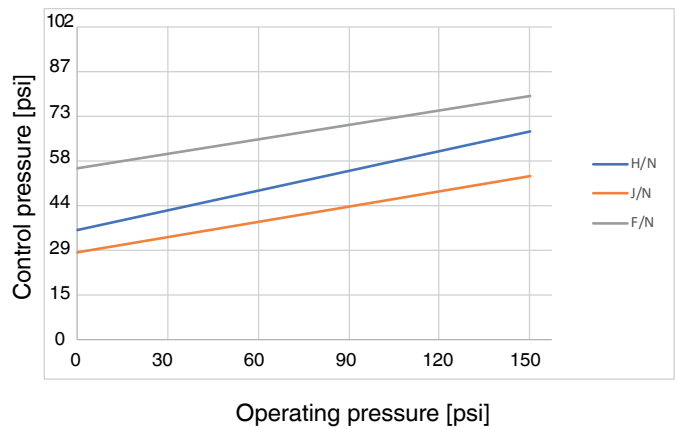

The control pressure depending on the prevailing operating pressure, as shown in the diagram, is intended as a guide for operating the system with low wear on the diaphragm.

Order data

Nominal size		Code
DN 10	NPS 3/8"	10
DN 12	G 3/8"	12
DN 15	NPS 1/2"	15
DN 20	NPS 3/4"	20
DN 25	NPS 1"	25
DN 32	NPS 1 1/4"	32
DN 40	NPS 1 1/2"	40
DN 50	NPS 2"	50
DN 65	NPS 2 1/2"	65
DN 80	NPS 3"	80
DN 100	NPS 4"	100

Body configuration	Code
Tank bottom valve body	B**
2/2-way body	D
T body	T*
* For dimensions see T Valves brochure	
** Dimensions and versions on request or according to customer requirements	

Connection	Code
Butt weld spigots	
Spigots DIN	0
Spigots EN 10357 series B (formerly DIN 11850 series 1)	16
Spigot EN 10357 series A (formerly DIN 11850 series 2) / DIN 11866 series A	17
Spigots DIN 11850 series 3	18
Spigots JIS-G 3447	35
Spigots JIS-G 3459	36
Spigots SMS 3008	37
Spigots BS 4825 Part 1	55
Spigot ASME BPE / DIN 11866 series C	59
Spigot ISO 1127 / EN 10357 series C / DIN 11866 series B	60
Spigots ANSI/ASME B36.19M Schedule 10s	63
Spigots ANSI/ASME B36.19M Schedule 40s	65
Threaded connections	
Threaded sockets DIN ISO 228	1
Threaded sockets NPT	31
Threaded spigots DIN 11851	6
One side threaded spigot, other side cone spigot and union nut, DIN 11851	62
Aseptic unions on request	
Flanges	
Flanges EN 1092 / PN16 / form B, length EN 558, series 1, ISO 5752, basic series 1	8
Flanges ANSI Class 150 RF, length MSS SP-88	38
Flanges ANSI Class 125/150 RF, length EN 558, series 1, ISO 5752, basic series 1	39
Clamp connections	
Clamps ASME BPE for pipe ASME BPE, length ASME BPE	80
Clamps DIN 32676 series B for pipe EN ISO 1127, length EN 558, series 7	82
Clamps ASME BPE for pipe ASME BPE, length EN 558, series 7	88
Clamps DIN 32676 series A for pipe DIN 11850, length EN 558, series 7	8A
Clamps SMS 3017 for pipe SMS 3008, length EN 558, series 7	8E
Aseptic clamps on request	
For overview of available valve bodies see page 14/15	

Valve body material	Code
EN-GJS-400-18-LT (SG iron 40.3) PFA lined	17
EN-GJS-400-18-LT (SG iron 40.3) PP lined	18
1.4435, investment casting	C3
1.4408, investment casting	37
1.4408, PFA lined	39
1.4435 (316L), forged body	40
1.4435 (BN2), forged body Δ Fe<0.5%	42
EN-GJS-400-18-LT (SG iron 40.3) hard rubber lined	83
1.4539, forged body	F4

Diaphragm material	Code
FKM	4
EPDM	13
EPDM	17
EPDM	19
EPDM	29
EPDM	36
PTFE/EPDM, one-piece	54
PTFE/EPDM, two-piece	5M
Material complies with FDA requirements, except code 4 and 29	

Control function	Code
Normally closed (NC)	1
Normally open (NO)	2
Double acting (DA)	3

Actuator version	Code
Diaphragm size 10	B/N
Diaphragm size 25	F/M
Diaphragm size 25	F/N
Diaphragm size 40	H/M
Diaphragm size 40	H/N
Diaphragm size 50	J/M
Diaphragm size 50	J/N
Diaphragm size 80	4/N
Diaphragm size 100	5/N
Diaphragm size 80, Control function 2	6A
Diaphragm size 80, Control function 1	6A2
Diaphragm size 100, Control function 2	7A
Diaphragm size 100, Control function 1	7A3
Diaphragm size 25 Control air connector in-line with flow direction	1RN
Diaphragm size 40 Control air connector in-line with flow direction	2RN
Diaphragm size 50 Control air connector in-line with flow direction	3RN
Diaphragm size 80 Control air connector in-line with flow direction	4RN
Diaphragm size 100 Control air connector in-line with flow direction	5RN

Available until April 2021	
Diaphragm size 25	1/N
Diaphragm size 40	2/N
Diaphragm size 50	3/N

Order data

Internal surface finishes for forged and block material bodies ¹

Readings for Process Contact Surfaces	Mechanically polished ²		Electropolished	
	Hygienic class DIN 11866	Code	Hygienic class DIN 11866	Code
Ra ≤ 31.5 μinch	H3	1502	HE3	1503
Ra ≤ 23.62 μinch	-	1507	-	1508
Ra ≤ 15.75 μinch	H4	1536	HE4	1537
Ra ≤ 9.84 μinch ³	H5	1527	HE5	1516

Readings for Process Contact Surfaces acc. to ASME BPE 2016 ⁴	Mechanically polished ²		Electropolished	
	ASME BPE Surface Designation	Code	ASME BPE Surface Designation	Code
Ra Max. = 30 μinch	SF3	SF3	-	-
Ra Max. = 25 μinch	SF2	SF2	SF6	SF6
Ra Max. = 20 μinch	SF1	SF1	SF5	SF5
Ra Max. = 15 μinch	-	-	SF4	SF4

Internal surface finishes for investment cast bodies

Readings for Process Contact Surfaces	Mechanically polished ²	
	Hygienic class DIN 11866	Code
Ra ≤ 248.03 μinch	-	1500
Ra ≤ 31.5 μinch	H3	1502
Ra ≤ 23.62 μinch ⁵	-	1507

¹ Surface finishes of customized valve bodies may be limited in special cases.

² Or any other finishing method that meets the Ra value (acc. to ASME BPE).

³ The smallest possible Ra finish for 1/4" (DN 8) BS 4825 Part 1 and ASME BPE is 15 μinch.

⁴ When using these surfaces, the bodies are marked according to the specifications of ASME BPE.

The surfaces are only available for valve bodies which are made of materials (e.g. GEMÜ material codes 40, 41, F4, 44) and use connections (e.g. GEMÜ connection codes 59, 80, 88) according to ASME BPE.

⁵ Not possible for GEMÜ connection code 59, DN 8 and GEMÜ connection code 0, DN 4.

Ra acc. to DIN EN ISO 4288 and ASME B46.1

Special function

Code

3-A compliant design

M

Order example	687	25	D	60	40	5M	1	1/N	1503	M
Type	687									
Nominal size		25								
Body configuration (code)			D							
Connection (code)				60						
Valve body material (code)					40					
Diaphragm material (code)						5M				
Control function (code)							1			
Actuator version (code)								1/N		
Surface finish (code)									1503	
Special function (code)										M

Dimensions [inch]

Actuator dimensions - control function 1

MG	Actuator size	ø B	B1	A	A1	G	Weight [lb]
10	B/N	2.64	1.73	4.92	2.44	G 1/4	1.2
25	1/N	5.04	-	6.46	2.56	G 1/4	4.4
	F/M, F/N	5.12	-	6.69	2.32	G 1/4	4.9
40	2/N	6.22	-	8.03	3.39	G 1/4	8.6
	H/M, H/N	6.73	-	8.19	2.95	G 1/4	10.4
50	3/N	8.39	-	9.61	3.82	G 1/4	15.4
	J/M, J/N	8.31	-	9.61	3.54	G 1/4	15.2
80	4/N	10.2	-	14.49	6.81	G 1/4	33.1
	6A2	14.17	-	18.7	6.22	G 1/4	114.6
100	5/N	10.2	-	14.65	6.65	G 1/4	35.5
	7A3	14.17	-	18.78	6.06	G 1/4	138.9

MG = diaphragm size

Control function 1 - Diaphragm size 10
Actuator size B/N

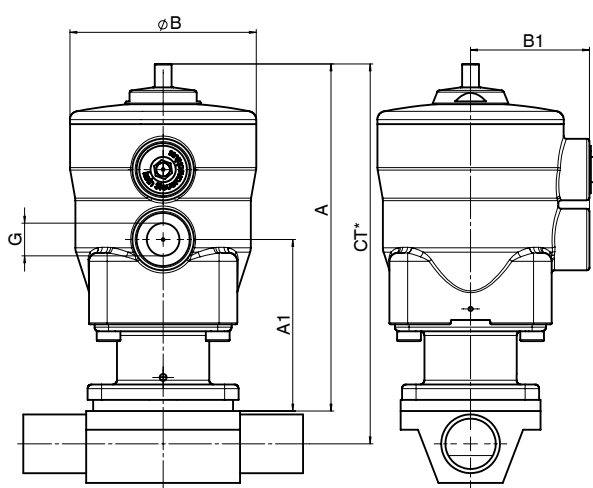

Control function 1 - Diaphragm size 25 - 100
Actuator size 1/N, 2/N, 3/N, 4/N, 6A2, 5/N, 7A3

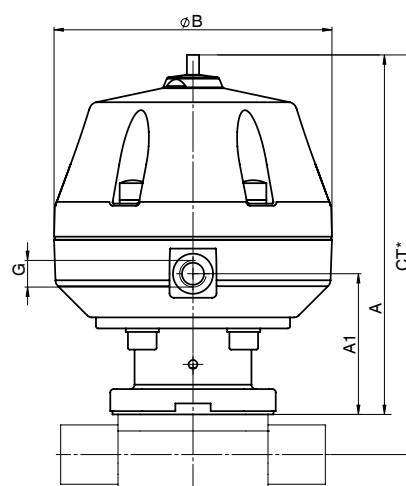

Control function 1 - Diaphragm size 25 - 50
Actuator size F/M, F/N, H/M, H/N, J/M, J/N

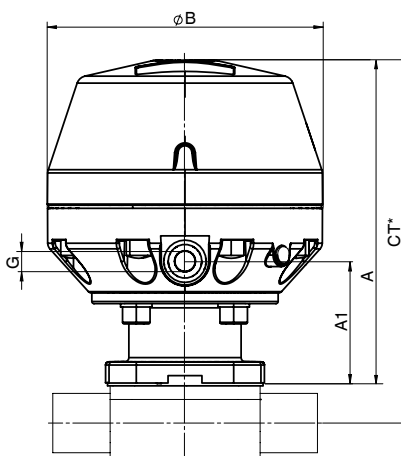

* CT = A + H1 (see body dimensions)

Dimensions [inch]

Actuator dimensions - control function 2 + 3

MG	Actuator size	ø B	A	A1	A2	B1	B2	G	Weight [lb]
10	B/N	2.24	4.33	1.93	1.18	1.38	2.68	G 1/4	-
25	1/N	5.04	4.61	2.6	1.1	-	-	G 1/4	-
	F/M, F/N	5.12	5.79	2.32	1.54	-	-	G 1/4	3.7
40	2/N	6.22	5.63	3.31	1.06	-	-	G 1/4	-
	H/M, H/N	6.73	6.81	2.95	1.65	-	-	G 1/4	6.8
50	3/N	8.39	6.57	3.78	1.1	-	-	G 1/4	-
	J/M, J/N	8.31	8.11	3.54	1.85	-	-	G 1/4	11.5
80	4/N	10.16	11.1	6.69	1.77	-	-	G 1/4	-
	6A	14.17	12.72	6.22	4.33	-	-	G 1/4	-
100	5/N	10.16	10.94	6.5	1.77	-	-	G 1/4	-
	7A	14.17	12.56	6.06	4.33	-	-	G 1/4	-

MG = diaphragm size

Control function 2 + 3 - Diaphragm size 10
Actuator size B/N

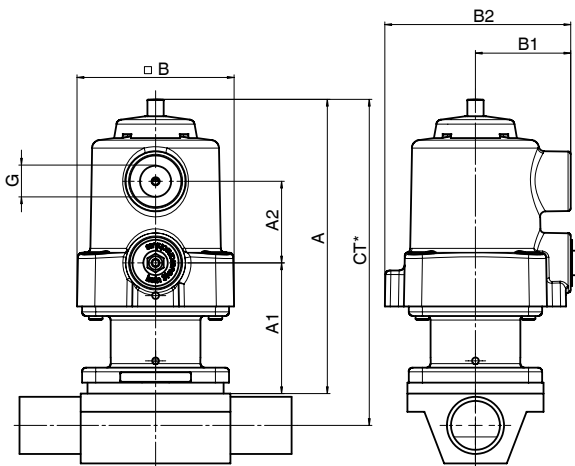

Control function 2 + 3 - Diaphragm size 25 - 100
Actuator size 1/N, 2/N, 3/N, 4/N, 6A2, 5/N, 7A3

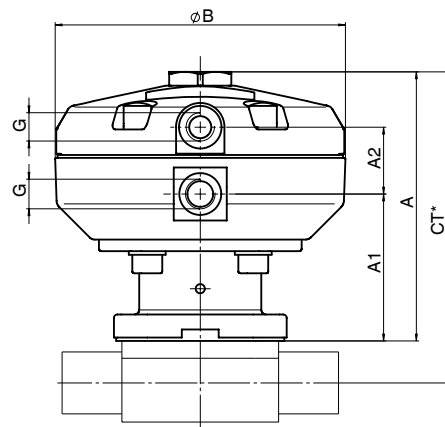

Control function 2 + 3 - Diaphragm size 25 - 50
Actuator size F/M, F/N, H/M, H/N, J/M, J/N

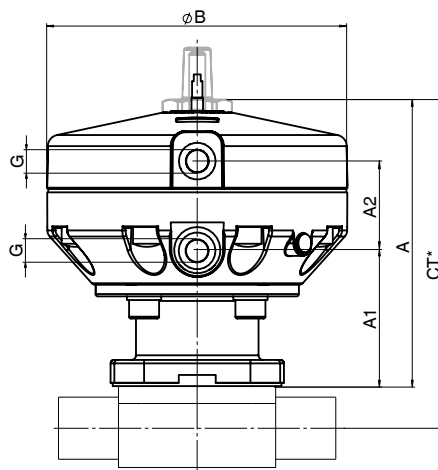

* CT = A + H1 (see body dimensions)

Body dimensions [inch]

Butt weld spigots, connection code 0, 16, 17, 18 Valve body material: Investment casting (code C3), forged body (code 40, F4)

Pipe standard							DIN		EN 10357 series B (formerly DIN 11850 series 1)		EN 10357 series A (formerly DIN 11850 series 2) / DIN 11866 series A		DIN 11850 series 3		Weight [lb]
Connection code							0		16		17		18		
MG	DN	NPS	L	c	H1*	H1**	ød	s	ød	s	ød	s	ød	s	
10	10	3/8"	4.25	0.98	0.49		-	-	0.47	0.04	0.51	0.06	0.55	0.08	0.66
	15	1/2"	4.25	0.98	0.49		0.71	0.06	0.71	0.04	0.75	0.06	0.79	0.08	0.66
25	15	1/2"	4.72	0.98	0.51	0.75	0.71	0.06	0.71	0.04	0.75	0.06	0.79	0.08	1.37
	20	3/4"	4.72	0.98	0.63	0.75	0.87	0.06	0.87	0.04	0.91	0.06	0.94	0.08	1.28
40	25	1"	4.72	0.98	0.75	0.75	1.1	0.06	1.1	0.04	1.14	0.06	1.18	0.08	1.21
	32	1 1/4"	6.02	0.98	0.94	1.02	1.34	0.06	1.34	0.04	1.38	0.06	1.42	0.08	3.2
50	40	1 1/2"	6.02	0.98	1.02	1.02	1.57	0.06	1.57	0.04	1.61	0.06	1.65	0.08	2.91
	50	2"	6.81	1.18	1.26	1.26	2.05	0.06	2.05	0.04	2.09	0.06	2.13	0.08	4.96
80	65	2 1/2"	8.5	1.18	-	2.44	-	-	-	-	2.76	0.08	-	-	18.96
	80	3"	10	1.18	-	2.44	-	-	-	-	3.35	0.08	-	-	17.64
100	100	4"	12.01	1.18	-	2.99	-	-	-	-	4.09	0.08	-	-	53.13

* only for investment cast design ** only for forged design MG = diaphragm size
For materials see overview on page 14

Butt weld spigots, connection code 60 Valve body material: Investment casting (code C3), forged body (code 40, F4)

Pipe standard							ISO 1127 / EN 10357 series C / DIN 11866 series B			Weight [lb]
Connection code							60			
MG	DN	NPS	L	c	H1*	H1**	ød	s		
10	10	3/8"	4.25	0.98	0.49	0.49	0.68	0.06	0.66	
	15	1/2"	4.25	0.98	0.49	0.49	0.84	0.06	0.66	
25	15	1/2"	4.72	0.98	0.51	0.75	0.84	0.06	1.37	
	20	3/4"	4.72	0.98	0.63	0.75	1.06	0.06	1.28	
40	25	1"	4.72	0.98	0.75	0.75	1.33	0.08	1.21	
	32	1 1/4"	6.02	0.98	0.94	1.02	1.67	0.08	3.2	
50	40	1 1/2"	6.02	0.98	1.02	1.02	1.9	0.08	2.91	
	50	2"	6.81	1.18	1.26	1.26	2.37	0.08	4.96	
80	65	2 1/2"	8.5	1.18	-	2.44	3	0.08	18.96	
	80	3"	10	1.18	-	2.44	3.5	0.09	17.64	
100	100	4"	12.01	1.18	-	2.99	4.5	0.09	53.13	

* only for investment cast design ** only for forged design MG = diaphragm size
For materials see overview on page 14

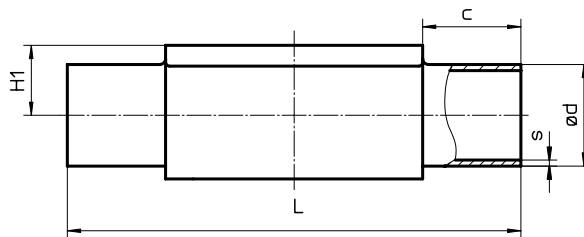

Body dimensions [inch]

Butt weld spigots, connection code 35, 36, 37 Valve body material: Investment casting (code C3), forged body (code 40, F4)

Pipe standard							JIS-G 3447		JIS-G 3459		SMS 3008		Weight [lb]
Connection code							35		36		37		
MG	DN	NPS	L	c	H1*	H1**	ød	s	ød	s	ød	s	
10	10	3/8"	4.25	0.98	-	0.49	-	-	0.68	0.06	-	-	0.66
	15	1/2"	4.25	0.98	-	0.49	-	-	0.85	0.08	-	-	0.66
25	15	1/2"	4.72	0.98	-	0.75	-	-	0.85	0.08	-	-	1.37
	20	3/4"	4.72	0.98	-	0.75	-	-	1.07	0.08	-	-	1.28
	25	1"	4.72	0.98	0.75	0.75	1	0.05	1.34	0.11	0.98	0.05	1.21
40	32	1 1/4"	6.02	0.98	-	1.02	1.25	0.05	1.68	0.11	1.33	0.05	3.2
	40	1 1/2"	6.02	0.98	1.02	1.02	1.5	0.05	1.91	0.11	1.5	0.05	2.91
50	50	2"	6.81	1.18	1.26	1.26	2	0.06	2.38	0.11	2.01	0.05	4.96
	65	2 1/2"	6.81	1.18	-	1.34	2.5	0.08	-	-	2.5	0.06	4.85
80	65	2 1/2"	8.5	1.18	-	2.44	2.5	0.08	3	0.12	2.5	0.06	18.96
	80	3"	10	1.18	-	2.44	3	0.08	3.51	0.12	3	0.06	17.64
100	100	4"	12.01	1.18	-	2.99	4	0.08	4.5	0.12	4	0.08	53.13

* only for investment cast design ** only for forged design MG = diaphragm size
For materials see overview on page 14

Butt weld spigots, connection code 55, 59, 63, 65 Valve body material: Investment casting (code C3), forged body (code 40, F4)

Pipe standard							BS 4825 Part 1		ASME BPE / DIN 11866 series C		ANSI/ASME B36.19M Schedule 10s		ANSI/ASME B36.19M Schedule 40s		Weight [lb]
Connection code							55		59		63		65		
MG	DN	NPS	L	c	H1*	H1**	ød	s	ød	s	ød	s	ød	s	
10	10	3/8"	4.25	0.98	-	0.49	0.38	0.05	0.38	0.04	0.67	0.06	0.67	0.09	0.66
	15	1/2"	4.25	0.98	-	0.49	0.5	0.05	0.5	0.06	0.84	0.08	0.84	0.11	0.66
	20	3/4"	4.25	0.98	0.49	0.49	0.75	0.05	0.75	0.06	-	-	-	-	0.66
25	15	1/2"	4.72	0.98	-	0.75	-	-	-	-	0.84	0.08	0.84	0.11	1.37
	20	3/4"	4.72	0.98	0.63	0.75	0.75	0.05	0.75	0.06	1.05	0.08	1.05	0.11	1.28
	25	1"	4.72	0.98	0.75	0.75	-	-	1	0.06	1.31	0.11	1.31	0.13	1.21
40	32	1 1/4"	6.02	0.98	-	1.02	-	-	-	-	1.66	0.11	1.66	0.14	3.2
	40	1 1/2"	6.02	0.98	1.02	1.02	-	-	1.5	0.06	1.9	0.11	1.9	0.14	2.91
50	50	2"	6.81	1.18	1.26	1.26	-	-	2	0.06	2.37	0.11	2.37	0.15	4.96
	65	2 1/2"	6.81	1.18	-	1.34	-	-	2.5	0.06	-	-	-	-	4.63
80	65	2 1/2"	8.5	1.18	-	2.44	-	-	2.5	0.06	2.87	0.12	2.87	0.2	18.96
	80	3"	10	1.18	-	2.44	-	-	3	0.06	3.5	0.12	3.5	0.22	17.64
100	100	4"	12.01	1.18	-	2.99	-	-	4	0.08	4.5	0.12	4.5	0.24	53.13

* only for investment cast design ** only for forged design MG = diaphragm size
For materials see overview on page 14

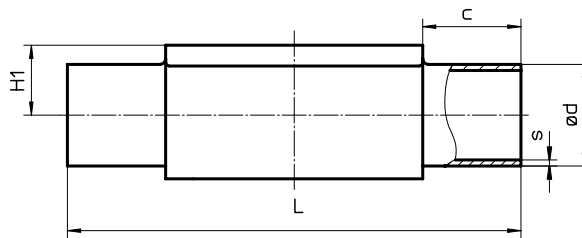

Body dimensions [inch]

Threaded sockets, connection code 1 Valve body material: Investment casting (code 37)

MG	DN	R	L	H	H1	t	SW2	Number of flats	Weight [lb]
10	12	G 3/8	2.17	0.98	0.51	0.47	22	2	0.37
	15	G 1/2	2.68	1.18	0.59	0.59	27	2	0.57
25	15	G 1/2	3.35	1.11	0.58	0.59	27	6	0.71
	20	G 3/4	3.35	1.31	0.68	0.63	32	6	0.75
	25	G 1	4.33	1.67	0.86	0.51	41	6	0.86
40	32	G 1 1/4	4.72	2.02	1.04	0.79	50	8	1.94
	40	G 1 1/2	5.51	2.22	1.13	0.71	55	8	2.05
50	50	G 2	6.5	2.81	1.43	1.02	70	8	3.44

MG = diaphragm size

Threaded sockets, connection code 31 Valve body material: Investment casting (code 37)

MG	DN	R	L	H	H1	t	SW2	Number of flats	Weight [kg]
25	15	NPT 1/2	3.35	1.11	0.58	0.55	27	6	0.71
	20	NPT 3/4	3.35	1.31	0.68	0.55	32	6	0.75
	25	NPT 1	4.33	1.67	0.86	0.67	41	6	0.86
40	32	NPT 1 1/4	4.72	2.02	1.04	0.67	50	8	1.94
	40	NPT 1 1/2	5.51	2.22	1.13	0.67	55	8	2.05
50	50	NPT 2	6.5	2.81	1.43	0.71	70	8	3.44

MG = diaphragm size

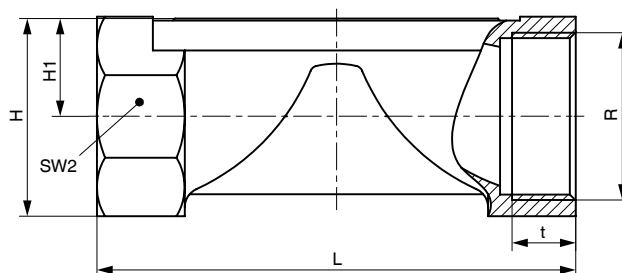

Body dimensions [inch]

Threaded connections, connection code 6, 62 Valve body material: Forged body (code 40)

MG	DN	H1	ød1	Thread to DIN 405 R	Code 6 L	Code 62 L	Weight [lb]
10	10	0.49	0.39	RD 28 x 1/8	4.65	4.57	0.73
	15	0.49	0.63	RD 34 x 1/8	4.65	4.57	0.77
25	15	0.75	0.63	RD 34 x 1/8	4.65	4.57	1.57
	20	0.75	0.79	RD 44 x 1/6	4.65	4.57	1.72
	25	0.75	1.02	RD 52 x 1/6	5.04	5	1.74
40	32	1.02	1.26	RD 58 x 1/6	5.79	5.79	3.66
	40	1.02	1.5	RD 65 x 1/6	6.3	6.3	3.57
50	50	1.26	1.97	RD 78 x 1/6	7.52	7.52	5.95
80	65	2.44	2.6	RD 95 x 1/6	9.69	9.69	20.33
	80	2.44	3.19	RD 110 x 1/4	10.08	10.08	20.28

MG = diaphragm size

Code 6

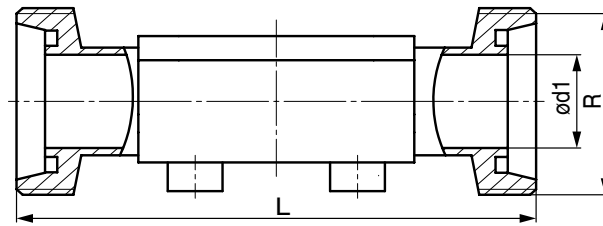

Code 62

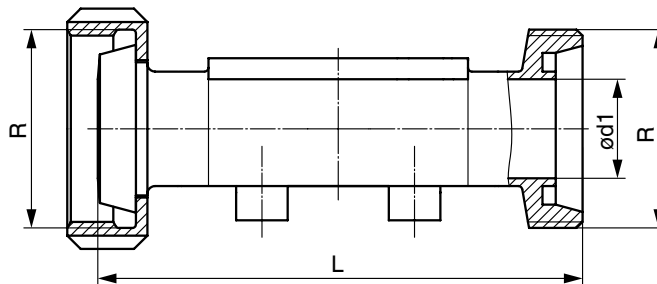

Body dimensions [inch]

Flanges - DIN EN 1092, connection code 8
 Valve body material: GGG 40.3 (code 17, 18, 83), investment casting (code C3),
 forged body (code 40), investment casting PFA lined (code 39)

MG	DN	øD	øk	øL	Number of bolts	H1			FTF	Weight [lb]
						Material code 17, 18, 39, 83	Material code C3	Material code 40		
25	15	3.74	2.56	0.55	4	0.71	0.51	0.75	5.12*	4.08
	20	4.13	2.95	0.55	4	0.81	0.63	0.75	5.91	5.18
	25	4.53	3.35	0.55	4	0.91	0.75	0.75	6.3	6.28
40	32	5.51	3.94	0.75	4	1.13	0.94	1.02	7.09	10.8
	40	5.91	4.33	0.75	4	1.3	1.02	1.02	7.87	12.46
50	50	6.5	4.92	0.75	4	1.54	1.26	1.26	9.06	16.42
80	65	7.28	5.71	0.75	4	2.01	-	2.44	11.42	22.49
	80	7.87	6.3	0.75	8	2.34	-	2.44	12.2	31.31
100	100	8.66	7.09	0.75	8	2.87	-	2.99	13.78	46.3

*Material code C3, 40 FTF = 5.91 (no DIN length)

MG = diaphragm size

For materials see overview on page 15

Flanges - ANSI Class 125/150 RF, connection code 38, 39
 Valve body material: GGG 40.3 (code 17, 18, 83), investment casting (code C3),
 forged body (code 40), investment casting PFA lined (code 39)

						H1			FTF			Weight [lb]
						Connection code 38, 39			MSS Sp-88 Connection-code 38		EN 558 Series 1 Connection-code 39	
MG	DN	øD	øk	øL	Number of bolts	Material code 17, 18, 39, 83	Material code C3	Material code 40	Material code 17, 18, 39, 83		Material code 17, 18, C3, 39, 40, 83	
25	15	3.54	2.37	0.63	4	0.71	0.51	0.75	-	-	5.12	4.08
	20	3.94	2.75	0.63	4	0.81	0.63	0.75	5.75	5.76	5.91	5.18
	25	4.33	3.13	0.63	4	0.91	0.75	0.75	5.75	5.76	6.3	6.28
40	32	4.53	3.5	0.63	4	1.13	0.94	1.02	-	-	7.09	10.8
	40	4.92	3.87	0.63	4	1.3	1.02	1.02	6.89	6.75	7.87	12.46
50	50	5.91	4.75	0.75	4	1.54	1.26	1.26	7.87	7.77	9.06	16.42
80	65	7.09	5.5	0.75	4	2.01	-	2.44	8.9	-	11.42	22.49
	80	7.48	6	0.75	4	2.34	-	2.44	10.24	10.25	12.2	31.31
100	100	9.06	7.5	0.75	8	2.87	-	2.99	12.87	12.77	13.78	46.3

MG = diaphragm size

For materials see overview on page 15

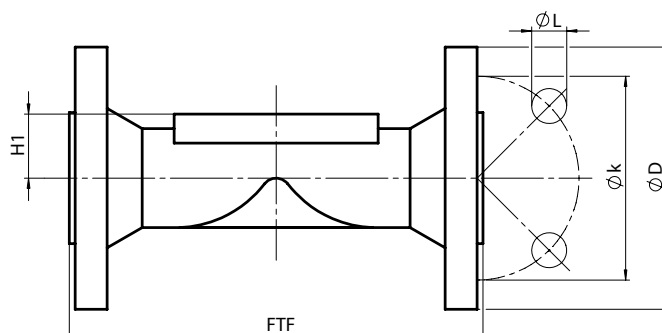

Body dimensions [inch]

Clamp connections, connection code 80, 82, 88, 8A, 8E Valve body material: Forged body (code 40, F4)

Pipe connection for clamp				ASME BPE						ISO 1127 / EN 10357 series C / DIN 11866 series B			EN 10357 series A (formerly DIN 11850 series 2) / DIN 11866 series A			SMS 3008			Weight [lb]
Clamp connection				ASME BPE						DIN 32676 series B			DIN 32676 series A			ISO 2852 / SMS 3017			
Clamp connection code				80			88			82			8A			8E			
MG	DN	NPS	H1	ød1	ød3	L	ød1	ød3	L	ød1	ød3	L	ød1	ød3	L	ød1	ød3	L	
10	10	3/8"	0.49	-	-	-	-	-	-	0.55	0.98	4.25	0.39	1.34	4.25	-	-	-	0.66
	15	1/2"	0.49	0.37	0.98	3.5	0.37	0.98	4.25	0.71	1.99	4.25	0.63	1.34	4.25	-	-	-	0.95
	20	3/4"	0.49	0.62	0.98	4	0.62	0.98	4.61	-	-	-	-	-	-	-	-	-	0.95
25	15	1/2"	0.75	-	-	-	-	-	-	0.71	1.99	4.25	0.63	1.34	4.25	-	-	-	1.65
	20	3/4"	0.75	0.62	0.98	4	0.62	0.98	4.61	0.93	1.99	4.61	0.79	1.34	4.61	-	-	-	1.57
	25	1"	0.75	0.87	1.99	4.5	0.87	1.99	5	1.17	1.99	5	1.02	1.99	5	0.89	1.99	5	1.39
40	32	1 1/4"	1.02	-	-	-	-	-	-	1.51	2.52	5.75	1.26	1.99	5.75	1.23	1.99	5.75	3.57
	40	1 1/2"	1.02	1.37	1.99	5.5	1.37	1.99	6.26	1.74	2.52	6.26	1.5	1.99	6.26	1.4	1.99	6.26	3.31
50	50	2"	1.26	1.87	2.52	6.25	1.87	2.52	7.48	2.22	3.05	7.48	1.97	2.52	7.48	1.91	2.52	7.48	5.51
	65	2 1/2"	1.34	2.37	3.05	7.63	2.37	3.05	8.5	-	-	-	-	-	-	2.37	3.05	8.5	5.07
80	65	2 1/2"	2.44	2.37	3.05	7.63	2.37	3.05	8.5	2.84	3.58	8.5	2.6	3.58	8.5	2.37	3.05	8.5	19.62
	80	3"	2.44	2.87	3.58	8.75	2.87	3.58	10	3.32	4.17	10	3.19	4.17	10	2.87	3.58	10	18.74
100	100	4"	2.99	3.83	4.69	11.5	3.83	4.69	12.01	4.32	5.12	12.01	3.94	4.69	12.01	3.84	4.69	12.01	54.67

MG = diaphragm size

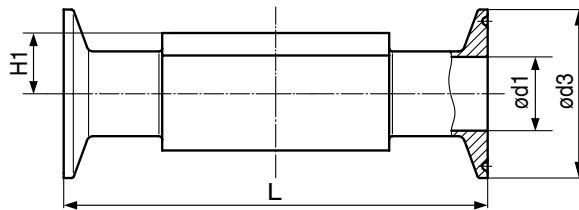

Overview of valve bodies for GEMÜ 687

		Spigots															
Connection code		0	16	17		18	35	36	37		55	59		60		63	65
Material code		40	40	C3	40	40	40	40	C3	40	40	C3	40	C3	40	40	40
MG	DN																
10	10	-	X	X	X	X	-	X	-	-	X	-	X	X	X	X	X
	15	X	X	X	X	X	-	X	-	-	X	-	X	X	X	X	X
	20	-	-	-	-	-	-	-	-	-	X	X	X	-	-	-	-
25	15	X	X	X	X	X	-	X	-	-	-	-	-	X	X	X	X
	20	X	X	X	X	X	-	X	-	-	X	X	X	X	X	X	X
	25	X	X	X	X	X	X	X	X	X	-	X	X	X	X	X	X
40	32	X	X	X	X	X	X	X	-	X	-	-	-	X	X	X	X
	40	X	X	X	X	X	X	X	X	X	-	X	X	X	X	X	X
50	50	X	X	X	X	X	X	X	X	X	-	X	X	X	X	X	X
	65	-	-	-	-	-	X	-	-	X	-	-	X	-	-	-	-
80	65	-	-	-	X	-	X	X	-	X	-	-	X	-	X	X	X
	80	-	-	-	X	-	X	X	-	X	-	-	X	-	X	X	X
100	100	-	-	-	X	-	X	X	-	X	-	-	X	-	X	X	X

Availability of material code 42, F4: same as code 40
 MG = diaphragm size

Overview of valve bodies for GEMÜ 687

		Threaded connections				Clamps					Flanges																
Connection code		1	31	6	62	80	82	88	8A	8E	8						38				39						
Material code		37	37	40	40	40	40	40	40	40	17	18	C3	39	40	83	17	18	39	83	17	18	C3	39	40	83	
MG	DN																										
10	10	-	-	W	W	-	K	-	K	-	-	-	-	-	-	-	-	-	-	-	-	-	-	-	-	-	
	12	X	-	-	-	-	-	-	-	-	-	-	-	-	-	-	-	-	-	-	-	-	-	-	-	-	
	15	X	-	W	W	K	W	K	K	-	-	-	-	-	-	-	-	-	-	-	-	-	-	-	-	-	
	20	-	-	-	-	K	-	K	-	-	-	-	-	-	-	-	-	-	-	-	-	-	-	-	-	-	
25	15	X	X	W	W	-	W	-	K	-	X	X	W	X	W	X	-	-	-	-	X	X	W	X	W	X	
	20	X	X	W	W	K	K	K	K	-	X	X	W	X	W	X	X	X*	X	X	X	X	W	X	W	X	
	25	X	X	W	W	K	K	K	K	K	X	X	W	X	W	X	X	X*	X	X	X	X	W	X	W	X	
40	32	X	X	W	W	-	W	-	K	K	X	X	W	X	W	X	-	-	-	-	X	X	W	X	W	X	
	40	X	X	W	W	K	W	K	K	K	X	X	W	X	W	X	X	X*	X	X	X	X	W	X	W	X	
50	50	X	X	W	W	K	W	K	K	K	X	X	W	X	W	X	X	X*	X	X	X	X	W	X	W	X	
	65	-	-	-	-	W	-	W	-	W	-	-	-	-	-	-	-	-	-	-	-	-	-	-	-	-	
80	65	-	-	W	W	K	K	K	K	K	-	-	-	-	W	-	-	-	-	-	-	-	-	-	W	-	
	80	-	-	W	W	K	W	K	W	K	X	X	-	X	W	X	X	X*	X	X	X	X	-	X	W	X	
100	100	-	-	-	-	W	W	W	W	W	X	X	-	X	W	X	X	X*	X	X	X	X	-	X	W	X	

* Connection code 38 / material code 18 on request

X = Standard

K = Connections completely machined (not welded)

W = Welded construction

Availability of material code 42, F4: same as code 40

MG = diaphragm size

Overview of diaphragm materials for GEMÜ 687

Diaphragm size	Diaphragm material				
	FPM	EPDM	EPDM	EPDM	PTFE/EPDM
10	4	13	14	17	52
25	4	13	14	17	5E
40	4	13	14	17	5E
50	4	13	14	17	5E
80	4	13	14	17	5E
100	4	13	14	17	52

For further metal diaphragm valves, accessories and other products, please see our Product Range catalogue and Price List. Contact GEMÜ.

GEMÜ VALVES, MEASUREMENT AND CONTROL SYSTEMS

